

PRODUCT INFORMATION PACKET

marathon[®]
Motors

Model No: 215TTFBA6007
Catalog No: GT1418
10,3600,TEFC,215TC,3/60/575
Totally Enclosed Fan Cooled (TEFC)



Regal and Marathon are trademarks of Regal Beloit Corporation or one of its affiliated companies.
©2018 Regal Beloit Corporation, All Rights Reserved. MC017097E

REGAL[®]

Nameplate Specifications

Output HP	10 Hp	Output KW	7.5 kW
Frequency	60 Hz	Voltage	575 V
Current	9.2 A	Speed	3540 rpm
Service Factor	1.15	Phase	3
Efficiency	90.2 %	Duty	Continuous
Insulation Class	F	Design Code	B
KVA Code	H	Frame	215TC
Enclosure	Totally Enclosed Fan Cooled	Overload Protector	No
Ambient Temperature	40 °C	Drive End Bearing Size	6307
Opp Drive End Bearing Size	6208	UL	Recognized
CSA	Y	CE	Y
IP Code	55		

Technical Specifications

Electrical Type	Squirrel Cage Inverter Rated	Starting Method	Line Or Inverter
Poles	2	Rotation	Reversible
Mounting	Rigid Base	Motor Orientation	Horizontal
Drive End Bearing	Ball	Opp Drive End Bearing	Ball
Frame Material	Rolled Steel	Shaft Type	T
Overall Length	21.02 in	Shaft Diameter	1.375 in
Shaft Extension	3.38 in	Assembly/Box Mounting	F1/F2 Capable
Outline Drawing	SS620297-215TC	Connection Diagram	EE7300

This is an uncontrolled document once printed or downloaded and is subject to change without notice. Date Created: 10/08/2018

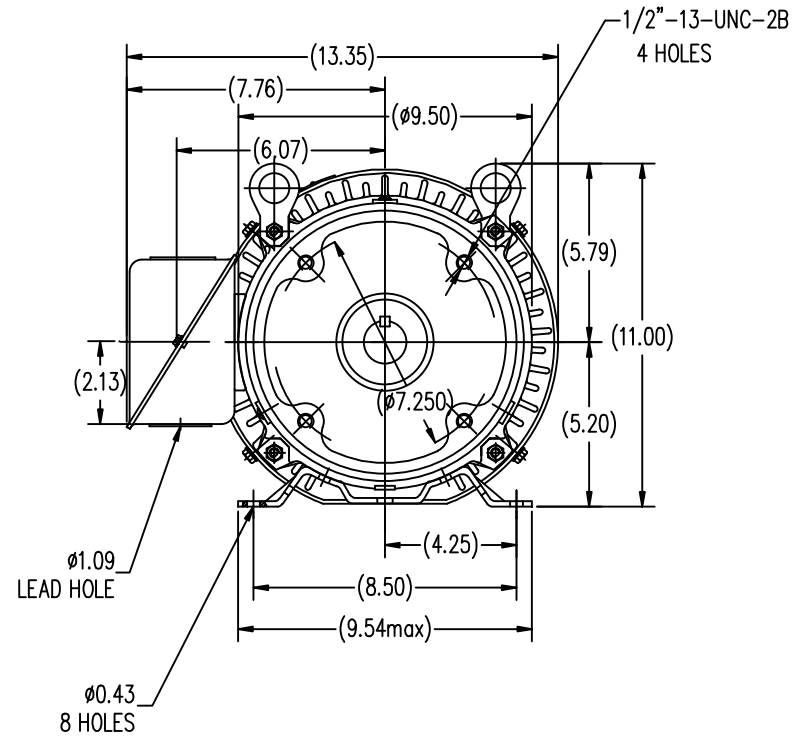
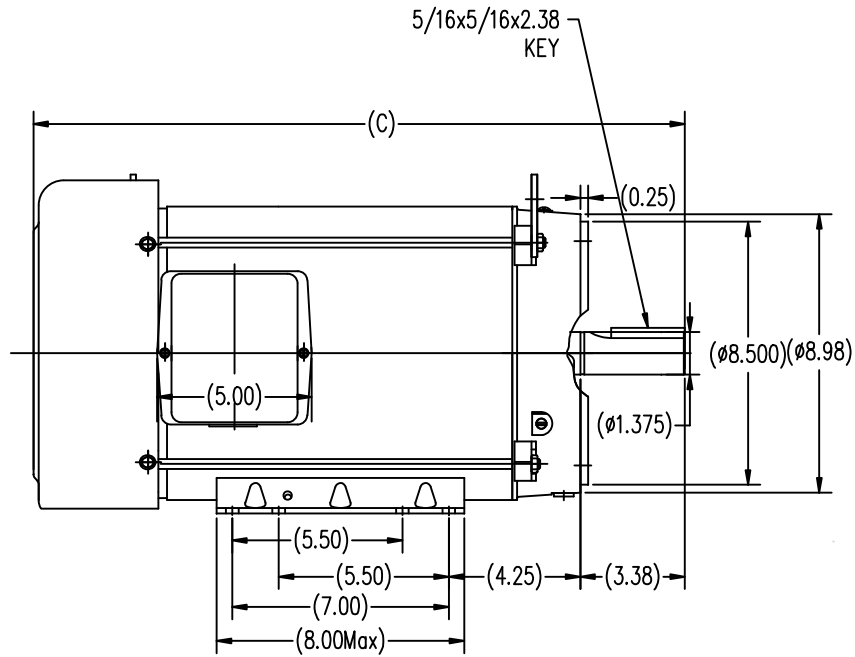

213TC	19.53
215TC	21.02
FRAME	C

TOLERANCES UNLESS SPECIFIED		REGAL-BELOIT CORPORATION		DRAWN SY 04-16-2010	
DEC.	INCHES	REGAL-BELOIT CORPORATION		CHK	HZJ 04-16-2010
.X	±.1	TITLE		APPD	CL 04-16-2010
.XX	±.03	NEMA-PREMIUM TTFBA 213T/215TC		SCALE	1=4
.XXX	±.005	MAT'L		REF	
.XXXX	±.0005	FINISH		FMF	HWADA
NO.	REVISION	BY & DATE	CHK	ANG	±1/2
THIS DRAWING IN DESIGN AND DETAIL IS OUR PROPERTY AND MUST NOT BE USED EXCEPT IN CONNECTION WITH OUR WORK. ALL RIGHTS OF DESIGN AND INVENTION ARE RESERVED. THIS IS AN ELECTRONICALLY GENERATED DOCUMENT - DO NOT SCALE THIS PRINT			RFP	CAD FILE	SS620297
			DIST	SIZE	B
			DRAWING NO.		SS620297
			REV.		

**THREE PHASE - SINGLE VOLTAGE
MOTOR - CONDUIT BOX @ 'A'**

**TO REVERSE ROTATION:
INTERCHANGE ANY TWO
LINE LEAD CONNECTIONS.**

TERMINAL BLOCK WHEN SPECIFIED



VIEW OF TERMINAL END

**IF MOTOR HAS
6 LEADS**

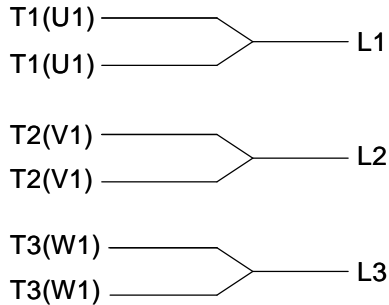

A-9806 DECAL

**OPTIONAL CORD
CONNECTION**

- L1 _____ WHITE
- L2 _____ RED
- L3 _____ BLACK

DRAWING REVISION AB	REVISION BY JJB	DATE 06-27-2017
ECO ECO-0125361	APPROVED BY TB	DATE 06-27-2017
ECO DESCRIPTION UPDATED TO CURRENT STANDARDS		
<small>COPYRIGHT REGAL BELOIT AMERICA, INC. ALL RIGHTS RESERVED. PROPRIETARY AND CONFIDENTIAL INFORMATION - THIS DOCUMENT IS THE PROPERTY OF REGAL BELOIT AMERICA, INC. ("OWNER") AND CONTAINS OWNER'S PROPRIETARY INFORMATION. ANY PERSON, CORPORATION OR OTHER FIRM RECEIVING IT IS DEEMED, BY RECEIVING IT, TO AGREE THAT IT, AND/OR ANY PART OF IT, SHALL NOT BE DISCLOSED TO ANY PERSON, CORPORATION OR OTHER ENTITY, DUPLICATED, AND/OR USED, EXCEPT AS EXPRESSLY APPROVED IN WRITING IN ADVANCE BY OWNER. THIS DOCUMENT SHALL BE RETURNED TO OWNER UPON REQUEST. IT MAY BE SUBJECT TO CERTAIN RESTRICTIONS UNDER APPLICABLE EXPORT CONTROL LAWS AND REGULATIONS.</small>		



DRAWN BY DA
DATE 03-26-1993
APPROVED BY TB
DATE 03-26-1993
REFERENCE
THIRD ANGLE PROJECTION

Regal Beloit America, Inc.	
MATERIAL	PROCESS/FINISH
SIZE A	DRAWING NUMBER EE7300
SHEET 1 OF 1	

